

EVEREST: CARATTERISTICHE GENERALI - GENERAL FEATURES

Vasca Tank	Accumulo Capacity (kWh) / (kcal)	Serpentine Serpentines (quantity)	Volume Volume (litre)	Dimensioni Dimensions (mm)			Attacchi Fittings				Soffiante Blower (kW)	
				L	Hv	Ht	M	SF	TP	R		
45	45 / 38700	1 x 3	2150	880	1785	2235	2"		1"	Ø 75	0,8	
60	60 / 51600	1 x 4	2150								0,8	
90	90 / 77400	1 x 6	2150								0,8	
130	130 / 111800	1 x 6	3800	1060	2345	2535	2"		1"	Ø 75	0,8	
180	180 / 154800	1 x 8	3800								0,8	
220	220 / 189200	1 x 10	5550								0,8	
260	260 / 223600	1 x 12	5550	1500	2405	2535	3"	2"	2"	1 x 3"	0,8	
310	310 / 266600	1 x 14	7350	1500							2535	2,2
350	350 / 301000	1 x 16	7350	1940							2590	2,2
440	440 / 378400	2 x 10	9100	1940	2405	2590	3"	2"	2"	1 x 3"	2,2	
530	530 / 455800	2 x 12	10900	2380							2590	2,2
620	620 / 533200	2 x 14	12700	2820							2630	2,2
700	700 / 602000	2 x 16	14450	3700	2405	2630	4"	2"	2"	1 x 3"	2,2	
880	880 / 756800	4 x 10	18050	4580							2630	2,2
1060	1060 / 911600	4 x 12	21600	5460							2690	3
1230	1230 / 1057800	4 x 14	25150	6340	2445	2730	4"	3"	3"	1 x 4"	3	
1400	1400 / 1204000	4 x 16	28700	7220							2730	3
1600	1600 / 1376000	6 x 12	32300	8100							2770	3
1900	1900 / 1634000	6 x 14	27650	9420	2445	3010	5"	3"	3"	2 x 3"	3	
2100	2100 / 1806000	6 x 16	42950	10740							3010	4,3
2500	2500 / 2150000	8 x 14	50100	12500							3010	4,3

TIPOLOGIE ESECUTIVE - TYPICAL LAY-OUT

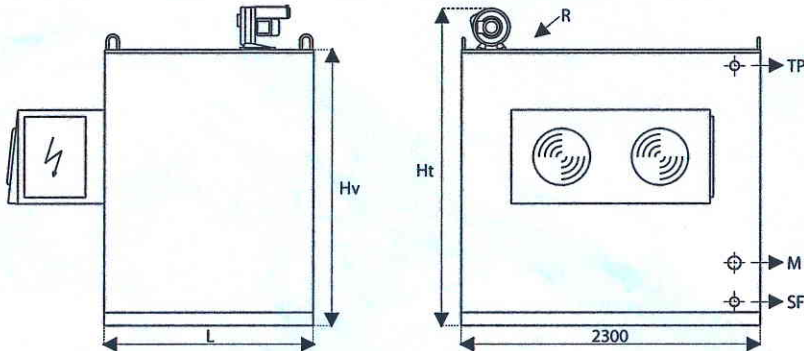

TIPO A / TYPE A: Vasca con gruppo frigo premontato / Tank with premounted cooling unit

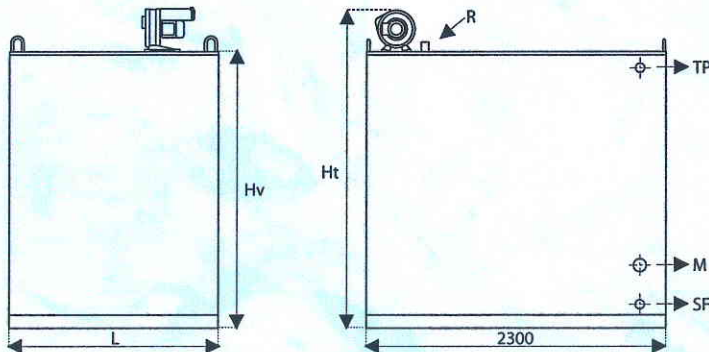

TIPO B / TYPE B: Vasca con gruppo frigo separati / Tank with remote cooling unit

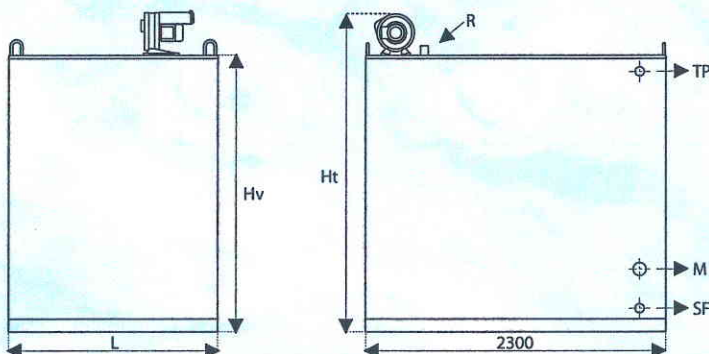
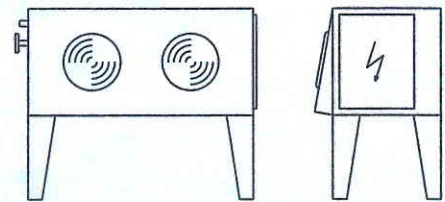

TIPO C / TYPE C: Vasca, unità e condensatore separati / Tank with remote condensing unit and remote condenser

